

LICENSING SUB-COMMITTEE

Date: Wednesday 26 October 2016
Time: 10.00 am
Venue: Bad Homburg Room, Civic Centre, Paris Street, Exeter

Members are invited to attend the above meeting to consider the items of business.

If you have an enquiry regarding any items on this agenda, please contact Howard Bassett, Democratic Services Officer (Committees) on 01392 265107 or email howard.bassett@exeter.gov.uk

Entry to the Civic Centre can be gained through the Customer Services Centre, Paris Street.

Membership -
Councillors Holland, Newby and Sills

Agenda

Part I: Items suggested for discussion with the press and public present

1 **Appointment of Chair**

To appoint a Chair for the meeting.

2 **Application for the renewal of a Private Hire Vehicle Licence ()**

<HEADING_LAYOUT_SECTION>

Application for the renewal of a Private Hire Vehicle Licence ()

</HEADING_LAYOUT_SECTION>

Application for the renewal of a Private Hire Vehicle Licence ()

</TITLED_COMMENT_LAYOUT_SECTION>

<SUBNUMBER_LAYOUT_SECTION>

a) **Application for the renewal of a Private Hire Vehicle Licence ()**

</SUBNUMBER_LAYOUT_SECTION>

<TITLE_ONLY_SUBNUMBER_LAYOUT_SECTION>

a) **Application for the renewal of a Private Hire Vehicle Licence ()**

</TITLE_ONLY_SUBNUMBER_LAYOUT_SECTION>

Find out more about Exeter City Council by looking at our website <http://www.exeter.gov.uk> . This will give you the dates of all future Committee meetings and tell you how you can ask a question at a Scrutiny Committee meeting. Alternatively, contact the Democratic Services Officer (Committees) on 01392 265107 for further information.

Follow us:

www.twitter.com/ExeterCouncil

www.facebook.com/ExeterCityCouncil

Individual reports on this agenda can be produced in large print on request to Democratic Services (Committees) on 01392 265111

3 Declarations of Interest

Councillors are reminded of the need to declare any disclosable pecuniary interests that relate to business on the agenda and which have not already been included in the register of interests, before any discussion takes place on the item. Unless the interest is sensitive, you must also disclose the nature of the interest. In accordance with the Council's Code of Conduct, you must then leave the room and must not participate in any further discussion of the item. Councillors requiring clarification should seek the advice of the Monitoring Officer prior to the day of the meeting.

4 LOCAL GOVERNMENT (ACCESS TO INFORMATION) ACT 1985 EXCLUSION OF PRESS AND PUBLIC

It is considered unlikely that the Committee would wish to exclude the press and public during consideration of the items on this agenda. If, however, the Committee were to exclude the press and public, a resolution in the following form should be passed:

“RECOMMENDED that, under Section 100A (4) of the Local Government Act 1972, the press and public be excluded from the meeting for the particular item(s) on the grounds that it (they) involve the likely disclosure of exempt information as defined in paragraph(s) of Part I of Schedule 12A of the Act.”

Part II: Item suggested for discussion with the press and public excluded

LOCAL GOVERNMENT (MISCELLANEOUS PROVISIONS) ACT 1976

5 Application for the renewal of a Private Hire Vehicle Licence (Mr EY)

To consider the report of the Assistant Director Environment.

(Pages 5 -
10)

6 Application for the renewal of a Private Hire Vehicle Licence (Mr KU)

To consider the report of the Assistant Director Environment.

(Pages 11
- 16)

7 Application for the grant of a Private Hire Vehicle Licence (Mr IM)

To consider the report of the Assistant Director Environment.

(Pages 17
- 30)

Individual reports on this agenda can be produced in large print on request to Democratic Services (Committees) on 01392 265107.

This page is intentionally left blank

REPORT TO LICENSING (SUB) COMMITTEE

Time and Date of Hearing: 26 OCTOBER 2016 PART 1 Matter

Report of: Environmental Health and Licensing Manager

Type of Application: Request to extend the licence relating to a Private Hire vehicle

Legislation: Local Government (Miscellaneous Provisions) Act 1976

Town Police Clauses Act 1847

Ward Application Refers to: Not Applicable

Applicant: Mr E YANAR

Premises Address: Not Applicable

1. What is the report about?

- 1.1 An application has been received from Mr Yanar the proprietor of a licensed Private Hire vehicle seeking permission to extend the licence for a further year. This is a matter that cannot be dealt with under delegated powers.

2. Are there any representations?

- 2.1 There is no provision in the legislation for anyone to submit representations relating to this kind of application.

3. Report details:

- 3.1 The vehicle, a Toyota Prius registration mark SD56 VJJ was first registered on 30 September 2006 making the vehicle over 10 years old so cannot be dealt with under delegated powers. The application is attached as Appendix A.
- 3.2 The recorded mileage of the vehicle at the time of the last MOT in September 2016 was 239476 miles.
- 3.3 Attached to the report is the current MOT (dated within 3 months) as Appendix B, the full inspection report as Appendix C.
- 3.4 The vehicle was checked by a Licensing Officer on 20 September 2016 and was found to be in a very good condition. The inspecting officer was advised that the upholstery on the seats had been replaced. Photographs of the vehicle will be available to view at the meeting.

4. What are the legal aspects?

- 4.1 The Licensing Sub-Committee are required only to ensure that Public safety is not compromised by the granting of an extension of the licence. If they are satisfied that safety is reasonably assured they may grant the licence for a maximum of 12 months or such shorter period as they see as appropriate.

5. Recommendations:

- 5.1 The Licensing Sub-Committee are asked to determine the application having regard to current policy.

Environmental Health and Licensing Manager

Local Government (Access to Information) Act 1972 (as amended)

Background papers used in compiling this report:-

None

Contact for enquires:

Democratic Services (Committees)

Room 2.3, 01392 265275

N.B THIS IS NOT PART OF THE REPORT

LOCAL GOVERNMENT (MISCELLANEOUS PROVISIONS) ACT 1976

HACKNEY CARRIAGE AND PRIVATE HIRE VEHICLE / DRIVERS LICENCES

You are invited to appear before the Licensing Sub-Committee to speak in support of your application. A legal or other adviser may accompany you but may not appear instead of you.

Your Application

Depending on the circumstances, your application may be heard in part two of the Committee meeting procedures from which members of the public and press are excluded. You will be notified in advance if your application will be a part two matter, if you have not been advised of this, the hearing will be in the Public domain.

You or your adviser would be expected to respond to an officer's verbal introduction outlining the above report. You or your adviser may be asked questions and may be invited to ask questions if appropriate.

At the end of the hearing you will be asked to withdraw and the Committee will reach a decision. On conclusion of the decision making process you will then be recalled and the decision announced.

By virtue of paragraph(s) 1, 2 of Part 1 of Schedule 12A
of the Local Government Act 1972.

Document is Restricted

This page is intentionally left blank



MOT Test Number

550902921326

Vehicle Registration Mark

SD56VJJ

Vehicle Identification Number

JTDKB20U507514189

Make

TOYOTA

Model

PRIUS

Colour

Silver

Issuer's Name

M. J. BAKER

Test Class

4

Country of Registration

Great Britain

Expiry Date

20 September 2017 (SEVENTEEN)

Issued

19 Sep 2016

Test Station

1AMA67

Odometer Reading and History

19 9 2016: 239476 mi
8 9 2015: 217562 mi
3 9 2014: 190311 mi
5 9 2013: 161777 mi

Inspection Authority

A1 MOT CENTRE
13 TEKOA UNITS
ALPHINBROOK ROAD
MARSH BARTON TRADING ESTATE
EXETER
EX2 8RG
01392 499300

Additional Information

To preserve the anniversary of the expiry date, the earliest you can present your vehicle for test is 21 August 2017.

Signature of Issuer

Advisory Information

001 Suspension arm rubber bush deteriorated but not resulting in excessive movement nearside front [2.4.G.2]
002 Suspension arm rubber bush deteriorated but not resulting in excessive movement nearside rear (axle bush) [2.4.G.2]
003 Suspension arm rubber bush deteriorated but not resulting in excessive movement offside rear (axle bush) [2.4.G.2]
004 Suspension arm rubber bush deteriorated but not resulting in excessive movement offside front [2.4.G.2]

About this document

- 1 This document is a receipt style certificate telling you that an MOT Test pass result has been recorded in the Driver & Vehicle Standards Agency's (DVSA's) database of MOT Test results; this can be verified at www.gov.uk/check-mot-status.
 - 2 A test certificate relates only to the condition of the components examined at the time of test. It does not confirm the vehicle will remain roadworthy throughout the validity period of the certificate.
 - 3 Check carefully that the details are correct.
 - 4 Whilst advisory items listed above do not constitute MOT failure items, they are drawn to your attention for advice.
 - 5 For further information about this document, please visit www.gov.uk/getting-an-mot or contact DVSA on 0300 123 9000*.
- *Your call may be monitored or recorded for lawful purposes.

BCS Check Sheet

APPENDIX C



Job Ref: 103797

Details

Name	Reg No. <u>SD56 UJT</u>	y/n
Telephone	Vehicle	Service book stamped <u>NA</u>
Date <u>19 SEPTEMBER 2016</u>	Mileage	Service light reset <u>NA</u>
<input checked="" type="checkbox"/> Visually OK	Date of next MOT <u>19/09/2016</u>	Vehicle washed & vacuumed <u>NA</u>
<input type="checkbox"/> Advisory		
<input type="checkbox"/> Needs urgent attention		

Service

Type of service completed FULL INSPECTION CHECK

Around the vehicle	<input type="checkbox"/>	<input type="checkbox"/>	<input type="checkbox"/>	Report	Suggested action
Horn	<input checked="" type="checkbox"/>				
Wipers	<input checked="" type="checkbox"/>				
Washers	<input checked="" type="checkbox"/>				
Instruments	<input checked="" type="checkbox"/>				
Brake lights	<input checked="" type="checkbox"/>				
Indicators	<input checked="" type="checkbox"/>				
Reversing lights	<input checked="" type="checkbox"/>				
Fog lights	<input checked="" type="checkbox"/>				
Headlights	<input checked="" type="checkbox"/>				
Number plate lights	<input checked="" type="checkbox"/>				

Under the bonnet	<input type="checkbox"/>	<input type="checkbox"/>	<input type="checkbox"/>	Report	Suggested action
Brake fluid level	<input checked="" type="checkbox"/>				
Coolant level	<input checked="" type="checkbox"/>				
Engine oil level	<input checked="" type="checkbox"/>				
Fan belt	<input checked="" type="checkbox"/>				

Raise vehicle

Depth mm

Near side	<input type="checkbox"/>	<input type="checkbox"/>	<input type="checkbox"/>	Outer	Middle	Inner	Pressure	Condition
Front tyre	<input checked="" type="checkbox"/>			<u>8mm</u>	<u>8mm</u>	<u>8mm</u>	<u>32</u>	<u>NEW</u>
Rear tyre	<input checked="" type="checkbox"/>			<u>5mm</u>	<u>6mm</u>	<u>5mm</u>	<u>32</u>	<u>GOOD</u>

Off side	<input type="checkbox"/>	<input type="checkbox"/>	<input type="checkbox"/>	Outer	Middle	Inner	Pressure	Condition
Front tyre	<input checked="" type="checkbox"/>			<u>8mm</u>	<u>8mm</u>	<u>8mm</u>	<u>32</u>	<u>NEW</u>
Rear tyre	<input checked="" type="checkbox"/>			<u>5mm</u>	<u>6mm</u>	<u>5mm</u>	<u>32</u>	<u>GOOD</u>

Boot / tailgate	<input type="checkbox"/>	<input type="checkbox"/>	<input type="checkbox"/>	Outer	Middle	Inner	Pressure	Condition
Check spare tyre	<input checked="" type="checkbox"/>			<u>7mm</u>	<u>6mm</u>	<u>7mm</u>	<u>34</u>	<u>GOOD</u>

Under the vehicle	<input type="checkbox"/>	<input type="checkbox"/>	<input type="checkbox"/>	Report	Suggested action
Pads / discs	<input checked="" type="checkbox"/>			<u>V. GOOD</u>	

Details of all work completed and Technician observations



Maximum Tyres Ltd
68-72 Hazel Road
Exeter Devon EX4 4LZ
01392 213322

[Handwritten Signature]

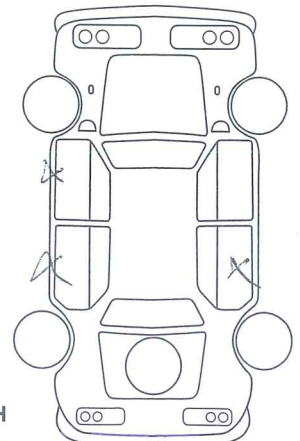

X = SCRATCH
O = DAMAGE

Technician Signature

Date 19/09/2016

REPORT TO LICENSING (SUB) COMMITTEE

Time and Date of Hearing: 26 OCTOBER 2016 PART 1 Matter

Report of: Environmental Health and Licensing Manager

Type of Application: Request to extend the licence relating to a Private Hire vehicle

Legislation: Local Government (Miscellaneous Provisions) Act 1976

Town Police Clauses Act 1847

Ward Application Refers to: Not Applicable

Applicant: Mr K UDDIN

Premises Address: Not Applicable

1. What is the report about?

- 1.1 An application has been received from Mr Uddin, the proprietor of a licensed Private Hire vehicle seeking permission to extend the licence for a further year. This is a matter that cannot be dealt with under delegated powers.

2. Are there any representations?

- 2.1 There is no provision in the legislation for anyone to submit representations relating to this kind of application.

3. Report details:

- 3.1 The vehicle, a Toyota Prius registration mark CY07 DSE was first registered on 25 May 2007 making the vehicle over 9 years old so cannot be dealt with under delegated powers. The application is attached as Appendix A.
- 3.2 The recorded mileage of the vehicle at the time of the last MOT in August 2016 was 283943 miles.
- 3.3 Attached to the report is the current MOT (dated within 3 months) as Appendix B, the full inspection report as Appendix C.
- 3.4 The vehicle was checked by a Licensing Officer on 27 September 2016 and was found to be in a satisfactory condition, although the body work had scratch marks on the front of the vehicle and on the side. Photographs of the vehicle will be available to view at the meeting.

4. What are the legal aspects?

- 4.1 The Licensing Sub-Committee are required only to ensure that Public safety is not compromised by the granting of an extension of the licence. If they are satisfied that safety is reasonably assured they may grant the licence for a maximum of 12 months or such shorter period as they see as appropriate.

5. Recommendations:

- 5.1 The Licensing Sub-Committee are asked to determine the application having regard to current policy.

Environmental Health and Licensing Manager

Local Government (Access to Information) Act 1972 (as amended)

Background papers used in compiling this report:-

None

Contact for enquires:

Democratic Services (Committees)

Room 2.3, 01392 265275

N.B THIS IS NOT PART OF THE REPORT

LOCAL GOVERNMENT (MISCELLANEOUS PROVISIONS) ACT 1976

HACKNEY CARRIAGE AND PRIVATE HIRE VEHICLE / DRIVERS LICENCES

You are invited to appear before the Licensing Sub-Committee to speak in support of your application. A legal or other adviser may accompany you but may not appear instead of you.

Your Application

Depending on the circumstances, your application may be heard in part two of the Committee meeting procedures from which members of the public and press are excluded. You will be notified in advance if your application will be a part two matter, if you have not been advised of this, the hearing will be in the Public domain.

You or your adviser would be expected to respond to an officer's verbal introduction outlining the above report. You or your adviser may be asked questions and may be invited to ask questions if appropriate.

At the end of the hearing you will be asked to withdraw and the Committee will reach a decision. On conclusion of the decision making process you will then be recalled and the decision announced.

By virtue of paragraph(s) 1, 2 of Part 1 of Schedule 12A
of the Local Government Act 1972.

Document is Restricted

This page is intentionally left blank



MOT Test Certificate

MOT Test Number 190207737512	Vehicle Registration Mark CY07DSE	Vehicle Identification Number JTDKB20U303224363
Make TOYOTA	Model PRIUS	Colour Red
Issuer's Name D. BRITTAIN	Test Class 4	Country of Registration Great Britain
Expiry Date 25 August 2017 (SEVENTEEN)	Issued 23 Aug 2016	Test Station V108653

Odometer Reading and History

23 8 2016: 283943 mi
26 8 2015: 248954 mi
3 9 2014: 218312 mi
9 9 2013: 193199 mi

Inspection Authority

SOWTON TYRES & MOT LTD
UNIT 4
KESTREL WAY
SOWTON INDUSTRIAL ESTATE
EXETER
EX2 7JS
01392 365511

Additional Information

To preserve the anniversary of the expiry date, the earliest you can present your vehicle for test is 26 July 2017.

Signature of Issuer

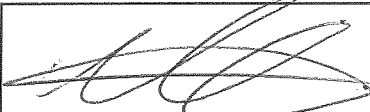

Advisory Information

001 registration plate faded but not likely to be misread [6.3.1d]
002 Nail in tyre nearside rear
003 (Underside of vehicle rusty)
004 (Nearside rear sill damaged/rusty)
005 (Slight oil leak transmission fluid)

About this document

- 1 This document is a receipt style certificate telling you that an MOT Test pass result has been recorded in the Driver & Vehicle Standards Agency's (DVSA's) database of MOT Test results; this can be verified at www.gov.uk/check-mot-status.
 - 2 A test certificate relates only to the condition of the components examined at the time of test. It does not confirm the vehicle will remain roadworthy throughout the validity period of the certificate.
 - 3 Check carefully that the details are correct.
 - 4 Whilst advisory items listed above do not constitute MOT failure items, they are drawn to your attention for advice.
 - 5 For further information about this document, please visit www.gov.uk/getting-an-mot or contact DVSA on 0300 123 9000*.
- *Your call may be monitored or recorded for lawful purposes.

VEHICLE INSPECTION

BE COMPLETED BY VEHICLE OPERATOR

OPERATOR NAME: Daniel Brittain EMAIL ADDRESS: Sowtonmots@yahoo.com
 SIGNATURE: [Signature] PHONE NUMBER: 07891543750 DATE: 27/9/16

INSPECTION POINT	PASS	FAIL
ADLIGHTS	<input checked="" type="checkbox"/>	<input type="checkbox"/>
FRONT LIGHTS	<input checked="" type="checkbox"/>	<input type="checkbox"/>
TURN INDICATOR LIGHTS	<input checked="" type="checkbox"/>	<input type="checkbox"/>
STOP LIGHTS	<input checked="" type="checkbox"/>	<input type="checkbox"/>
TYRE PADS/SHOES THICKNESS	<input checked="" type="checkbox"/>	<input type="checkbox"/>
Pressure, per Manufacturer		
Front Left Measurements		
Front Right Measurements		
Rear Left Measurements		
Rear Right Measurements		
EMERGENCY/PARKING BRAKE	<input checked="" type="checkbox"/>	<input type="checkbox"/>
STEERING MECHANISM	<input checked="" type="checkbox"/>	<input type="checkbox"/>
Ball Joints	<input checked="" type="checkbox"/>	<input type="checkbox"/>
Tie Rods	<input checked="" type="checkbox"/>	<input type="checkbox"/>
Rack & Pinion	<input checked="" type="checkbox"/>	<input type="checkbox"/>
Bushings	<input checked="" type="checkbox"/>	<input type="checkbox"/>
WINDSHIELD	<input checked="" type="checkbox"/>	<input type="checkbox"/>
Large Crack	<input type="checkbox"/>	<input type="checkbox"/>
Small Crack	<input type="checkbox"/>	<input type="checkbox"/>
FRONT WINDOW AND OTHER GLASS	<input checked="" type="checkbox"/>	<input type="checkbox"/>
WINDSHIELD WIPERS	<input checked="" type="checkbox"/>	<input type="checkbox"/>

1.6
 4.0
 4.0
 3.5
 3.5

INSPECTION POINT	PASS	FAIL
FRONT SEAT ADJUSTMENT	<input checked="" type="checkbox"/>	<input type="checkbox"/>
DOORS (Open/Close/Lock)	<input checked="" type="checkbox"/>	<input type="checkbox"/>
HORN	<input checked="" type="checkbox"/>	<input type="checkbox"/>
SPEEDOMETER	<input checked="" type="checkbox"/>	<input type="checkbox"/>
BUMPERS	<input checked="" type="checkbox"/>	<input type="checkbox"/>
MUFFLER AND EXHAUST SYSTEM	<input checked="" type="checkbox"/>	<input type="checkbox"/>
TIRES, INCL. TREAD DEPTH	<input type="checkbox"/>	<input type="checkbox"/>
Right Front (32nd's/in)	<input checked="" type="checkbox"/>	<input type="checkbox"/>
Left Front (32nd's/in)	<input checked="" type="checkbox"/>	<input type="checkbox"/>
Right Rear (32nd's/in)	<input checked="" type="checkbox"/>	<input type="checkbox"/>
Left Rear (32nd's/in)	<input checked="" type="checkbox"/>	<input type="checkbox"/>
INTERIOR AND EXTERIOR REAR VIEW MIRRORS	<input checked="" type="checkbox"/>	<input type="checkbox"/>
SAFETY BELTS FOR DRIVER AND EACH PASSENGER	<input checked="" type="checkbox"/>	<input type="checkbox"/>

VEHICLE INSPECTION RESULT
Inspector To Circle

PASS
FAIL

INSPECTION DATE: 27/09/16

Any markings on the "FAIL" side will automatically fail inspection.
THIS CERTIFICATION EXPIRES 1 YEAR FROM INSPECTION DATE

BE COMPLETED BY INSPECTOR

Sowton Mot s

COMPANY: Sowton mot s VEHICLE MILEAGE: 288435 01392 365511
 LICENSE PLATE STATE AND #: CY07 OSE VIN#: JTDEB20U303224363
 VEHICLE MAKE: Toyota VEHICLE MODEL: PRIUS MODEL YEAR: 2007 # OF DOORS: 5
 INSPECTOR NAME: Daniel Brittain INSPECTION ADDRESS: Unit 4 kestrel Business park
 INSPECTOR SIGNATURE: [Signature] STATE CERTIFICATION #:

REPORT TO LICENSING (SUB) COMMITTEE

Time and Date of Hearing: 26 OCTOBER 2016 PART 1 Matter

Report of: Environmental Health and Licensing Manager

Type of Application: Request for GRANT of a licence relating to a Private Hire vehicle.

Legislation: Local Government (Miscellaneous Provisions) Act 1976
Town Police Clauses Act 1847

Ward Application Refers to: Not Applicable

Applicant: Mr I MORADI

Premises Address: Not Applicable

1. What is the report about?

- 1.1 An application has been received from Mr Ibrahim Moradi the proprietor of a previously licensed Private Hire vehicle seeking permission for the GRANT of a licence as the vehicle is over 4 years. This is a matter that cannot be dealt with under delegated powers.

2. Are there any representations?

- 2.1 There is no provision in the legislation for anyone to submit representations relating to this kind of application.

3. Report details:

- 3.1 The vehicle, a Vauxhall Zafira according to the registration document is 4 years and 9 months old. The application is attached as Appendix A. Mr Moradi was out of the UK at the time the vehicle was due to be renewed and missed his renewal date. As a result of this the licence lapsed and was unable to be renewed under delegated powers.
- 3.2 The recorded mileage of the vehicle at the time of the last MOT in October 2016 was 72363 miles.
- 3.3 Attached to the report is the current MOT (dated within 3 months) as Appendix B, the full inspection report as Appendix C.
- 3.4 The vehicle was checked by a Licensing Officer on 14 October 2016 and was found to be in a very good condition. Photographs of the vehicle will be available for view at the meeting.

4. What are the legal aspects?

- 4.1 The Licensing Sub-Committee are required only to ensure that Public safety is not compromised by the granting of an extension of the licence. If they are satisfied that safety is reasonably assured they may grant the licence for a maximum of 12 months or such shorter period as they see as appropriate.

5. Recommendations:

- 5.1 The Licensing Sub-Committee are asked to determine the application having regard to current policy.

Environmental Health and Licensing Manager

Local Government (Access to Information) Act 1972 (as amended)

Background papers used in compiling this report:-

None

Contact for enquires:

Democratic Services (Committees)

Room 2.3, 01392 265275

N.B THIS IS NOT PART OF THE REPORT

LOCAL GOVERNMENT (MISCELLANEOUS PROVISIONS) ACT 1976

HACKNEY CARRIAGE AND PRIVATE HIRE VEHICLE / DRIVERS LICENCES

You are invited to appear before the Licensing Sub-Committee to speak in support of your application. A legal or other adviser may accompany you but may not appear instead of you.

Your Application

Depending on the circumstances, your application may be heard in part two of the Committee meeting procedures from which members of the public and press are excluded. You will be notified in advance if your application will be a part two matter, if you have not been advised of this, the hearing will be in the Public domain.

You or your adviser would be expected to respond to an officer's verbal introduction outlining the above report. You or your adviser may be asked questions and may be invited to ask questions if appropriate.

At the end of the hearing you will be asked to withdraw and the Committee will reach a decision. On conclusion of the decision making process you will then be recalled and the decision announced.

By virtue of paragraph(s) 1, 2 of Part 1 of Schedule 12A
of the Local Government Act 1972.

Document is Restricted

This page is intentionally left blank

APPENDIX B



Driver & Vehicle
Standards
Agency

MOT Test Certificate

MOT Test Number

560086541319

Vehicle Registration Mark

WF12ZMY

Vehicle Identification Number

W0L0AHM75C2090737

Make

VAUXHALL

Model

ZAFIRA

Colour

Black

Issuer's Name

R. J. CLARK

Test Class

4

Country of Registration

Great Britain

Expiry Date

10 October 2017 (SEVENTEEN)

Issued

11 Oct 2016

Test Station

77882

Odometer Reading and History

11 10 2016: 72363 mi
21 9 2015: 43230 mi
14 4 2015: 37276 mi

Inspection Authority

CENTRAL GARAGE SERVICES EXETER LTD
31-35 OLD TIVERTON ROAD
EXETER
EX4 6LG 01392 428088

Additional Information

To preserve the anniversary of the expiry date, the earliest you can present your vehicle for test is 11 September 2017.

Signature of Issuer

Advisory Information

Large empty rectangular box for advisory information.

About this document

- 1 This document is a receipt style certificate telling you that an MOT Test pass result has been recorded in the Driver & Vehicle Standards Agency's (DVSA's) database of MOT Test results; this can be verified at www.gov.uk/check-mot-status.
 - 2 A test certificate relates only to the condition of the components examined at the time of test. It does not confirm the vehicle will remain roadworthy throughout the validity period of the certificate.
 - 3 Check carefully that the details are correct.
 - 4 Whilst advisory items listed above do not constitute MOT failure items, they are drawn to your attention for advice.
 - 5 For further information about this document, please visit www.gov.uk/getting-an-mot or contact DVSA on 0300 123 9000*.
- *Your call may be monitored or recorded for lawful purposes.

Comprehensive Vehicle Inspection Report

Customer Details

Exeter Motor Works
Old Tiverton Road
Exeter

Report Date: 11/10/16

Report No: 9970

Customer's contact details

Home:

Work: 01392 210739

Mobile: 07810825111

VEHICLE DETAILS

Make VAUXHALL

Registration Number WF12 ZMY

Model ZAFIRA DESIGN CDTI ECOFLEX

Colour BLACK

Vehicle Identity Number (VIN) W0L0AHM75C2090737

VIN Checked and confirmed on vehicle
Yes X No

V5/Registration document available and checked No

MOT Certificate available and checked YES

Mileage reading In 72362
(Not guaranteed) Out 72360

MOT Expiry Date 10/10/17

Vehicle Excise Licence Expiry 01/04/17

Date of inspection 11/10/16

Time of inspection 14.20

Location of vehicle Exeter Motor Works, Old Tiverton Road, Exeter.

Lighting Good

Weather. Good
(See notes)

Ramp available. Yes No
(See notes)

SECURITY CHECK

The vehicle identification number on this vehicle was checked and found to be **consistent** with the manufacturer's format.

SUMMARY REPORT

X READY FOR USE – No faults found, suitable for immediate use.

ADVISABLE REPAIRS ONLY – Suitable for immediate use but advisable repairs should be planned for.

ESSENTIAL AND ADVISABLE REPAIRS REQUIRED – Not suitable unless all essential repairs are undertaken and advisable repairs, if any are planned for.

UNSATISFACTORY – Vehicle has significant deficiencies, which are judged to be impractical or uneconomical to repair to a satisfactory standard.

Please read all pages of this report

KEY:

- S satisfactory
- R repainted
- = scratch
- X dent
- O corrosion
- C chip / rust
- P previous repairs

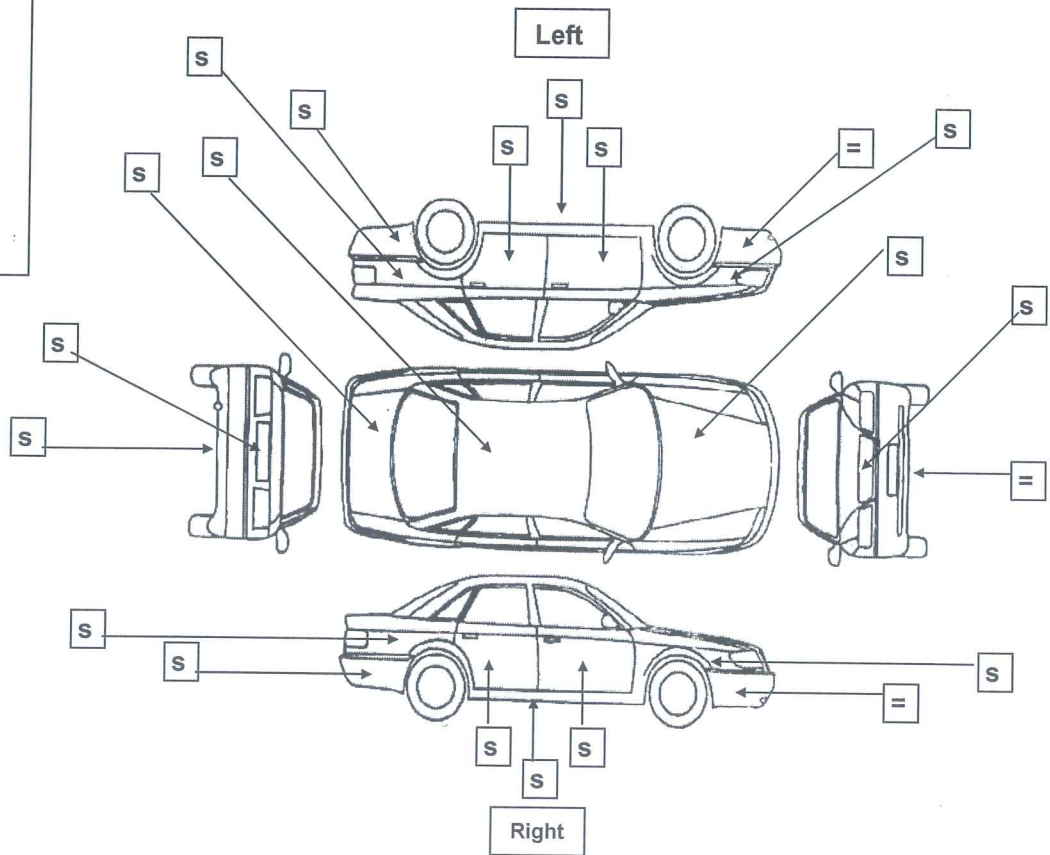

Minor blemishes, which are acceptable fair wear and tear for the vehicle's age, recorded mileage and type, are not recorded and you should satisfy yourself in this regard.

EVIDENCE OF BODYWORK REPAIRS	Yes	No X
BODYWORK CLEAN AND DRY	Yes X	No (See Notes)

Comments

The exterior body condition was good and commensurate with the vehicles age and recorded mileage.

KEY FOR POINTS ON FOLLOWING PAGES

- S Satisfactory for age and recorded mileage
- Could not be checked
- x Essential repair requiring immediate attention
- A Advisable repair should be considered prior to purchase
- N/A Not applicable
- Y Yes
- N No

Please note: Right = Off side (O/S) and Left = Near side (N/S) as viewed from the driver's seat.

BODY EXTERIOR

1. Panel Condition / alignment	S	6. Door locks - operation	S	11. Mud flaps	S
2. Paintwork	S	7. Fuel filler cover and cap	S	12. Body panels	S
3. Exterior trim /grille	S	8. Soft top / Hard top (operation)	N/A	13. Bonnet catch	S
4. Glass	S	9. Body damage	S	14. Bonnet hinges	S
5. Bumpers / No plates – Ft / Rr	S	10. Corrosion	No	No	

ENGINE COMPARTMENT
PETROL **DIESEL** **MULTI-FUEL**
No. of CYLINDERS: 4

15. Coolant Level / Condition	S	22. Power Steering – oil level	S	29. Turbo / supercharger	--
16. Coolant leaks	No	23. Clutch Fluid	S	30. Fuel pump / pipes	S
17. Antifreeze *	S	24. Brake Fluid	S	31. Accelerator linkage	S
18. Radiator / Cap	S	25. Engine Oil level	S	32. Cold starting	--
19. Hoses / Pipes	S	26. External leaks (upper engine)	S	33. Fast idle (cold)	--
20. Drive Belts	--	27. Engine mountings	S	34. Noise level (cold)	--
21. Water Pump (Not visible)	--	28. Fuel Injection	S	35. Excess fumes / smoke	No

Note - To ensure future serviceability, it is important that the engine camshaft belt is replaced at intervals specified by the manufacturer. It is in your best interests you ensure that this is carried out. * Antifreeze only has a 2/3 year life span and requires its strength adjusting after this time or replacing as per manufacturers specifications.

ELECTRICAL / CONTROLS

36. Starting system / Ignition lock	S	41. Rear lights & No. plate lights	S	49. Instruments	S
37. Battery condition	S	42. Stop lights	S	50. Horn	S
38. Battery voltages:	S	43. Indicator/ Hazard lights	S	51. Radio/Cass/CD/Aerial	S
- Normal 12.55 volts	S	44. Reverse / Fog lights	S	52. Heater / Fan controls	S
- Starting 10.98 volts	S	45. Auxiliary lights	N/A	53. Air Con operation	S
- Charging 14.10 volts	S	46. Interior / Panel lights	S	54. Windows / Sun roof	S
39. Headlights	S	47. Mirrors (electric)	S	55. Wipers / Washers	S
40. Sidelights / running lights	S	48. Controls / Switches	S	56. Headlamp wash / wipe	N/A

Note - We are unable to verify dash panel light and switch back lighting operation due to the daylight conditions. Please note that switching them "on or off" only assesses electrical components. Accuracy of instruments cannot be assessed.

INTERIOR / LUGGAGE COMPARTMENT**NUMBER OF SEATS: 7**

57. Steering Wheel / Adjustment	S	64. Door seals / hinges	S	71. Rear parcel shelf / load cover	--
58. Seat upholstery	S	65. Interior sills	S	72. Boot / tailgate lock	S
59. Seat adjustment	S	66. Headlining / visors	S	73. Luggage area trim con	S
60. Seatbelts	S	67. Sun roof	N/A	74. Illumination light	S
61. Carpets / Mats	S	68. Dash panel (condition)	S	75. Tool kit	S
62. Door trim panels	S	69. Cigarette lighter	N/A	76. Hard / Soft top (condition)	N/A
63. Door fittings / operation	S	70. Mirrors (internal)	S	77. Tonneau cover	N/A

FRONT SUSPENSION / STEERING / UNDER FRAME

78. Engine underside leakage	No	83. Wheel hubs / bearings	S	88. Sub-frames mountings	S
79. Steering joints/ ball joints	S	84. Springs/suspension units	S	89. Suspension arms / mountings	S
80. Steering rack / box	S	85. Pipes / hoses	S	90. Tie bars / anti roll bars	S
81. Chassis members	S	86. Dampers (condition / leaks)	S	91. Corrosion protection	Yes
82. Power steering (operation)	S	87. Gaiters	S	92. Corrosion – floor/chassis	No

REAR SUSPENSION / UNDER FRAME

93. Springs/suspension bars	S	97. Location rods/fixings	N/A	101. Sub-frames/ mountings	S
94. Anti roll bar	S	98. Bump stops/gaiters	N/A	102. Chassis members	S
95. Dampers/bushes	S	99. Wheel hubs/bearings	S	103. Corrosion protection	Yes
96. Suspension arms/fixings	N/A	100. Pipes/hoses	N/A	104. Corrosion – floor/chassis	No

CLUTCH / TRANSMISSION
MANUAL **AUTOMATIC**
MULTI-USE / 4x4 **SIX SPEED GEARBOX**

105. Fluid / oil leaks	No	109. Casings	S	113 Backlash	S
106. Cables / adjustments	N/A	110. Mountings	S	114. Gaiters	S
107. Hydraulic system	S	111. Drive shaft assembly	S	115. Propshaft(s) / fittings	N/A
108. Linkage (wear)	S	112. Universal / sliding joints	S	116. Bearings / supports	N/A

EXHAUST SYSTEM

117. Manifold	S	120. Silencer(s)	S	123. System condition	S
118. Pipes	S	121. Heat shields / mountings	S		
119. Catalytic converter (s)	S	122. Joints / couplings	S		

FUEL SYSTEM

124. Tank	S	126. Fuel lines	S	128. Evidence of leaks	No
125. Tank fixings	S	127. Breather pipes	S		

BRAKES

129. Master cylinder security	S	132. Flexible hoses	S	135. Handbrake op / adjustment	S
130. Fluid leaks	No	133. Pipes / connections	S	136. Handbrake mechanism	S
131. Servo / power system	S	134. Discs / pads (if visible)	S	137. Pedal and pad / linkage	S

Note - If the vehicle is fitted with brake drums the internal parts including linings are not visible. Brake fluid should be replaced at the manufacturers specified intervals.

WHEELS AND TYRES Type: Alloy

It is recommended tyres be replaced when the tread depth reaches 2mm. If uneven tyre wear is noted, this may indicate incorrect geometry, which can result in excessive and rapid tyre wear. A full steering and geometry check is recommended.

138. Wheel Rims	S
139. Wheel Trims	S

Tyres	Make	Size	Type / Construction	Min tread depth	
140. Front RH	Autogrip	205/55/16	Radial	7.0mm	S
141. Front LH	Autogrip	205/55/16	Radial	7.0mm	S
142. Rear LH	Autogrip	205/55/16	Radial	7.0mm	S
143. Rear RH	Autogrip	205/55/16	Radial	5.3mm	S
144. Spare	Comet	205/55/16	Radial	1.5mm	S

145. ROAD TEST

The road test has been undertaken within the speed limits and prevailing traffic conditions in the locality of the inspection. If a road test has not been carried out, please refer to the engineer's comments page.

*If the vehicle is fitted with 4wd transmission then the systems have been checked for security, leakage and excessive noise. However, within the limitations of the road test the full functionality could not be checked.

Test Distance 3 Miles

Speed achieved up to 40 MPH

146. Final drive operation / Noise level	S	153. Instrument /controls function	No	160. Road holding / stability	S
147. Gearbox operation / Noise level	S	154. Steering wheel alignment	S	161. General steering / handling	S
148. Engine performance	S	155. 4WD operation *	N/A	162. Footbrake operation	S
149. Engine noise	S	156. Clutch operation **	S	163. Hand/park brake operation	S
150. Excess smoke	No	157. Cooling fan operation	S	164. Suspension noise	No
151. Overheating evidence	No	158. Steering effort	S	165. Warning lights	S
152. Auto changes / kick-down	N/A	159. Hot restarting	S	166. Cruise control	S

** It should be carefully noted that the life expectancy of clutches is uncertain and difficult to predict, being dependant on owners driving style, vehicle operation and terrain. The fact that the clutch has not been identified as faulty/slipping/juddering/noisy on the report does not and should no be taken to imply that the clutch assembly will have a continuing life expectancy from the time of our check. They can begin to slip at any time.

FINAL CHECK

167. Oil leaks	No	168. Coolant leaks	No	169. Uneven tyre wear	No
----------------	----	--------------------	----	-----------------------	----

Report No: 9970

Vehicle documents and Inspection environment notes.

Engineer Indicate with "X" as applicable.

Registration Document (V5):

- No registration document was seen with the vehicle and you are advised to satisfy yourself that the vehicle identification number and engine number (where quoted) correspond to those shown on this report. Warning: **DO NOT BUY ANY VEHICLE WITHOUT A V5.**
- The V5/Registration Document shows _____ previous keeper(s), the last change of Keeper on _____

Security:

- The Master Key was not available. Please ensure this is supplied if the vehicle is purchased.
- The engineer recommends that relevant spare and service keys be obtained prior to purchase.
- Obtain hand books and radio codes for vehicle prior to purchase as these were not seen in the vehicle.

M O T:

- As only a small amount of time is left on the MOT Certificate (less than 3 months) the engineer recommends a full year's MOT be obtained prior to purchase.
- A full year Certificate has been seen with the vehicle.

Servicing:

- The service history seen, indicated that the last recorded service was carried out at miles. No immediate servicing is necessary. Next service is due as per manufacturer's recommendations or as per the Vehicles Service indicator.
- The service history seen, indicated that the last recorded service was carried out on the _ at miles. Therefore the engineer would suggest a full service and brake inspection to the manufacturer recommendations prior to purchase, which may reveal further defects not apparent at this examination.
- No service documentation seen with this vehicle and therefore the engineer would recommend a full service and brake inspection to the manufacturer's recommendations prior to purchase, which may reveal further defects not apparent at this examination.

Inspection conditions notes:

- No vehicle hoist/ramp was available. A large trolley jack and stands were used in order to carry out underside checks. This limits the view of the underside. Some areas could not be fully seen. There *may* be further defects, which may be visible given clear access and view.
- The body/paintwork was wet/dirty/dusty this severely restricts inspection of the paintwork. Please note that there may be other defects present, which were not visible due to the obscured paintwork, but which may become visible once dry and clean.

Report No: 9970

Engineers Comments

The vehicle is considered overall to be a fair and reasonable example of the type, being in a generally reasonable condition and generally considered to be consistent with the type for the age and indicated recorded mileage in most areas.

The items listed as "could not be checked" (---) normally indicate items were obscured by covers/shields or other equipment.

The Water pump – Engine drive belt/chain - these items could not been fully examined, as covers, trims and other equipment obscure them.

The cooling system was pressure tested to 0.7 bars, no pressure loss was noted on the system or pressure cap. The antifreeze concentration was an acceptable, but has deteriorated from its original strength and at the next routine service may need to be refreshed/replaced. It is advised that the coolant strength be checked again at the next routine service. Antifreeze only has a 2/3-year life and requires its strength adjusting after this time or replacing as per manufacturer's specifications.

The vehicle is fitted with vented front brake disc and pads, supported at the rear by a single arrangement. Although the visible brakes only show some signs of general serviceable wear, some deterioration is noted, which will need attention in the near future. It is strongly advised to remove all road wheels and examine the inner brake components, which are obscured on this vehicle prior to purchase, replacing any worn or badly corroded parts. It is probable that the front brakes at least, will need to be replaced at the next routine service.

The braking system's fluid contains the presence of some water/condensation in the system. It is recommended that the fluid content is completely replaced at the next service interval.

The steering & suspension has been assessed to MOT standard. This allows for a degree of wear and deterioration of components without rendering them unserviceable. The extent of wear is not considered excessive at this juncture and unlikely to attract MOT failure.

The road test distance and or top speed was limited due to the general area/inspection location, and/or traffic levels and/or adverse weather conditions and/or lack of fuel when the vehicle was tested and driven. Comment cannot be made in these instances in relation to possible "high speed" or "sustained speed," related driving defects, which may become apparent at a later stage after any purchase due to these limiting conditions.

Report No: 9970

It is strongly advised that the essential defects are investigated and rectified prior to purchase.

Item	Comment
------	---------

Additional Comments

No vehicle hoist/ramp was available. A large trolley jack and stands were used in order to carry out underside checks. This limits the view of the underside somewhat. Some areas could not be fully seen. There may be further defects, which may be visible given clear underside access and view.

The exhaust has been identified, as having limited life because, although there is no leakage present, there is some external corrosion present and the inside of the system, which may have significant deterioration, cannot be inspected internally.

Please note that a service is recommended, this may reveal repairs or maintenance requirements that could not be identified due to the constraints of a visual and external examination of the vehicle carried out without the benefit of a vehicle hoist.

Report No: 9970

This page is intentionally left blank